



- Giunti di elevata qualità serie "S".
High quality joints series "S".

- Lunghezze min. e max. a richiesta:
Min. and max. lengths on request:

$$L. MIN. \geq \frac{L. MAX. + 2 L2 + B}{2}$$

$$CORSA X \geq \frac{L. MAX. - 2 L2 - B}{2}$$

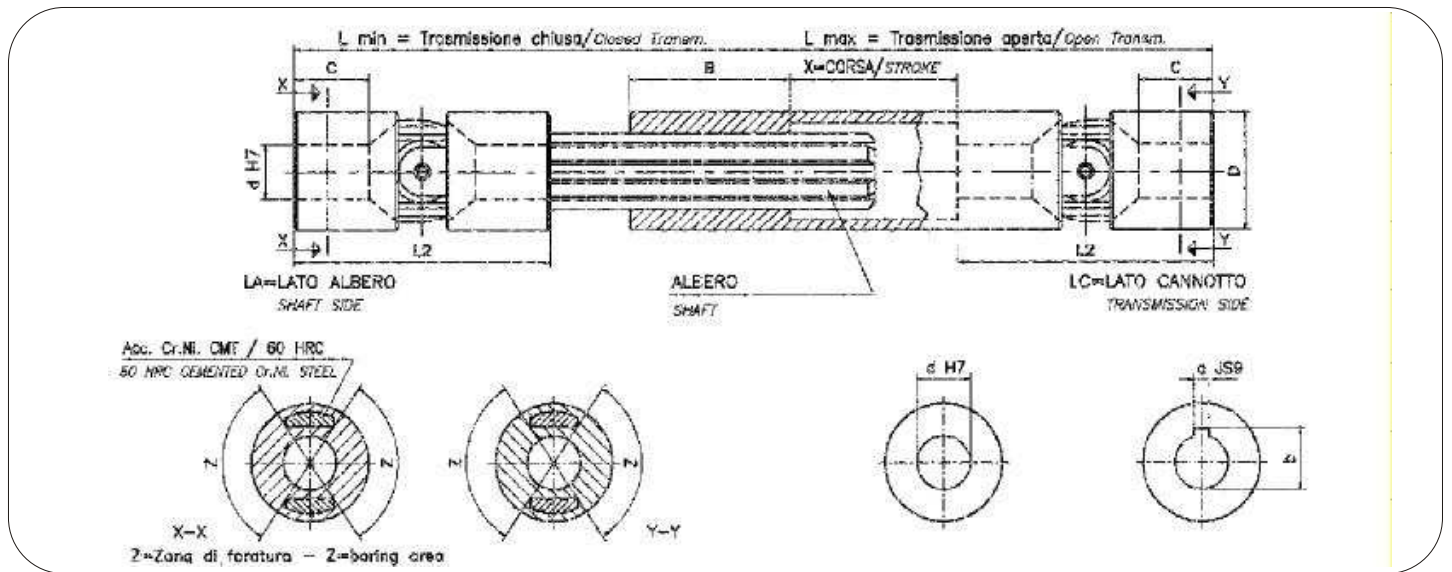

Mod. Type	d	D	L2	C	L min.	L max.	x = corsa / stroke	B	a	b	Albero Shaft
					a richiesta - on request						
01A	6	16	34	9	←	→	—	25	—	—	SW 8
02A	8	18	40	11	←	→	—	25	—	—	SW 10
03A	10	22	48	14	←	→	—	30	3	11,4	11 x 14 Z6
04A	12	26	56	16	←	→	—	40	4	13,8	13 x 16 Z6
05A	14	29	60	17	←	→	—	40	5	16,3	13 x 16 Z6
1A	16	32	68	20	←	→	—	40	5	18,3	16 x 20 Z6
2A	18	37	74	21	←	→	—	40	6	20,8	18 x 22 Z6
3A	20	42	82	23	←	→	—	45	6	22,8	21 x 25 Z6
4A	22	47	95	25	←	→	—	45	6	24,8	23 x 28 Z6
5A	25	52	108	29	←	→	—	45	8	28,3	26 x 32 Z6
6A	30	58	122	34	←	→	—	50	8	33,3	32 x 38 Z8