



Rexnord® Pin & Bush

Precision. Power. Performance.

You want a trusted name when it comes to providing engineered power transmission products that improve productivity and efficiency. Rexnord provides superior products for your industrial applications world wide. We work closely with you to reduce maintenance costs, eliminate redundant inventories and prevent equipment downtime.

Applications include:

- ▶ conveyors
- ▶ industrial fans
- ▶ crushers
- ▶ compressors

Pin & Bush

Close coupled elastomeric pin and bushing coupling providing economical high torque capacity. Torque range from 2000 Nm up to 270.000 Nm. Low inventory requirements due to the Pin & Bush symmetrical coupling design.

Rexnord Pin & Bush

Features

- ▶ Loaded in compression
- ▶ Fail safe design
- ▶ No lubrication required

Benefits

- ▶ High torque
- ▶ Continued operation
- ▶ Maintenance free

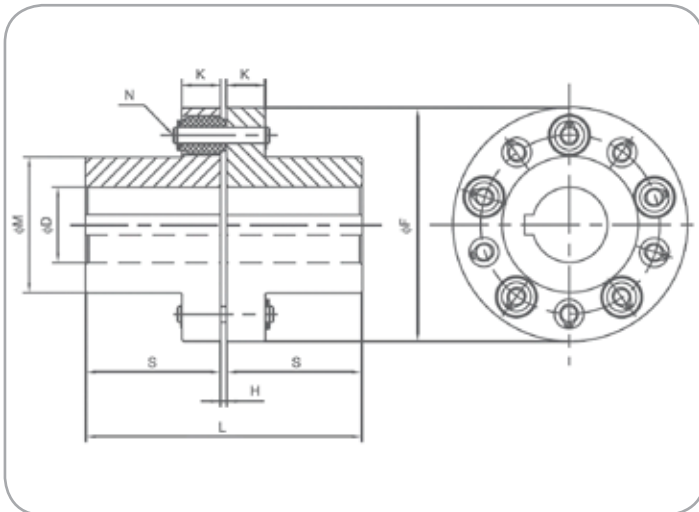
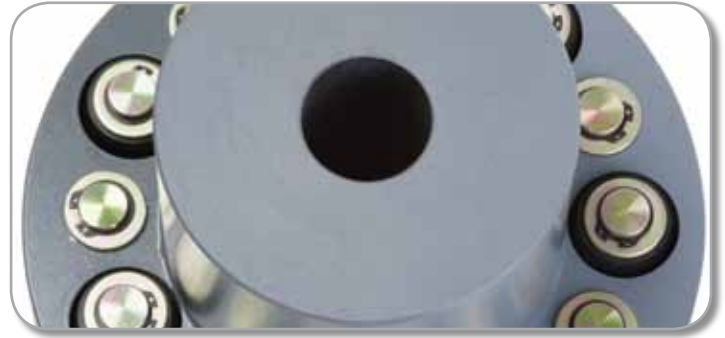

Torque Demands Driven Machine	Typical Application for Electric Motor or Turbine Driven Equipment	Typical Service Factor
	Constant torque such as centrifugal pumps blowers and compressors	1.0
	Continuous duty with some torque variations including plastic extruders and forced draft fans	1.3
	Light shock loads from metal extruders, cooling towers and log haulers	1.5
	Moderate shock loading as expected from a car dumper, stone crusher, vibrating screen	2.0
	Heavy shock load with some negative torques from reciprocating pumps, compressors, reversing turnout tables	2.5
	Frequent torque reversals such as reciprocating compressors with frequent torque reversals which do not necessarily include reverse rotations	Consult Rexnord Engineering

Size	Tnom	n-max	Dmin	Dmax	F	S	L	M	H	K	Inertia kgcm ²	m kg
E225B	2000	3200	40	90	225	130	264	145	4	25	0,127	47
E250B	3560	3000	45	95	250	150	305	147	5	38	0,220	55
E300B	5000	2500	50	110	300	180	365	182	5	38	0,541	85
E350B	8100	2200	60	120	350	200	406	200	6	60	1,26	130
E400B	11200	1800	70	140	400	220	446	232	6	60	2,28	190
E450B	16200	1600	75	160	450	240	487	253	7	72	3,84	260
E500B	21500	1400	75	180	500	260	527	288	7	72	6,17	350
E550B	27700	1200	80	210	550	280	567	322	7	72	9,37	450
E630B	57700	1000	130	250	630	280	567	375	7	90	19,0	710
E680B	73000	900	150	270	680	280	567	405	7	90	26,8	980
E800B	112300	760	180	280	800	300	607	420	7	90	47,1	1100
E900B	153800	680	200	300	900	300	607	448	7	90	77,0	1250
E1100B	270000	600	280	350	1100	400	807	550	7	100	204	2520



REXNORD NV, Belgium
 Dellingsstraat 55
2800 Mechelen
 Phone: +32 / 15 44 38 11
 Fax: +32 / 15 44 38 60
 E-mail: CSB@rexnord.com
www.rexnord.eu

Contact